

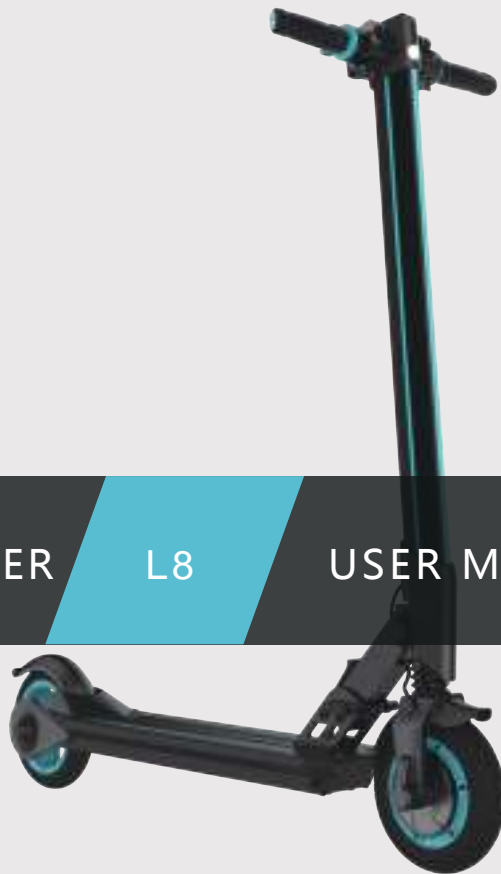

INMOTION E-SCOOTER

L8

USER MANUAL



INMOTION TECHNOLOGIES CO.,LTD
www.imscv.com

***i*NMOTION**

Catalog

1.	Introduction	3
1.1.	Overview	3
1.2.	Related Documents and Materials	3
1.3.	Signs and Words of Caution	3
2.	Product Overview	4
2.1.	Product Serial No.	4
2.2.	Product Dimensions	4
2.3.	Product Parameters	5
2.4.	Product Structure	6
2.5.	Packing Carton Check	7
2.6.	Open L8	7
2.7.	Display Screen	9
2.8.	INMOTION APP	10
2.9.	Pairing with INMOTION APP	10
2.10.	Scooter Working Modes	11
3.	Battery and Charger	12
3.1.	Battery Specifications	12
3.2.	Charging Method	12
3.3.	Safety Prompt for Charging	13
3.4.	Protection against Over-discharging	13
4.	How to Use L8	14

4.1.	Riding L8	14
4.2.	Precautions before driving	14
4.3.	Operating steps of beginners	15
4.4.	Body folding steps	15
4.5.	Switch lamp and active power off	16
5.	Precautions for Safe driving process	16
6.	Care and Maintenance	17
6.1.	Storage	17
6.2.	Cleaning	17
6.3.	Handling	17
6.4.	Inflation and Replacement of the Interior and Exterior Tires	17
6.5.	Handlebar loosening adjustment	18
7.	Contact and Legal Information	18
7.1.	Feedback of issues	18
7.2.	Contact Us	18
7.3.	Following the Local Laws	18
7.4.	Version No.	18
8.	Legal Statement	19
8.1	Statement about the Product	19
8.2	Personal Information Protection Statement	21
8.3	Intellectual Property Statement	22
9.	Product Warranty	23
	Product Warranty Card	26
	Certificate of Quality	28

1. Introduction

1.1. Overview

For your driving safety , please read this manual carefully before using L8 and ensure to be able to drive L8 under the correct guidance.

- Learning all the safety warnings and precautions listed in this manual that will be helpful for you to better control the L8.
- This manual is applicable to INMOTION E-scooter products manufactured by Shenzhen INMOTION Technology Co.,Ltd.
- If you have any questions or you cannot find the information you require from this manual, please contact in time the dealer authorized by INMOTION or the after-sale service department of INMOTION Company.

1.2. Related Documents and Materials

The document in PDF format for "User Manual" of L8, INMOTION APP and other help files can be downloaded from the official web site of Shenzhen INMOTION Technology Co., Ltd. : www.imscv.com.

1.3. Signs and Words of Caution

The following descriptions are applicable all through this manual, and the "Warnings" and "Notes" deserve your special attention.



WARNING!

Warns you about actions that may result in personal injury.



NOTE:

Identifies important points, helpful hints, special circumstances, or alternative methods.

2. Product Overview

L8 is a cool, highly efficient and economical personal travel tool. With its stylish and futuristic appearance, superb shock mitigation design and powerful lithium battery, L8 is created to give you a wonderful riding experience.

2.1. Product Serial No.

A serial No. is a product's unique identity, used for quality tracking, after-sales service, insurance claiming, identification of a lost product, etc. Make sure to keep a record of the serial No. and take care not to lose it. You can find the serial No. of the product at the following positions: the outer packing, the warranty card, and the body of L8 (to be more specifically, it's located at structure of the Body folding).

2.2. Product Dimensions

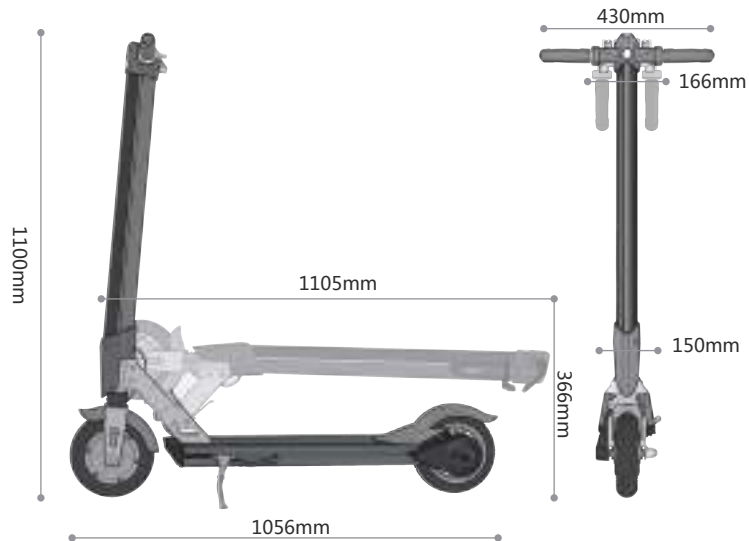

2.3. Product Parameters

Product model	L8	L8F	Remarks ① You can set the maximum cruising speed with mobile telephone APP. The maximum cruising speed is measured at the temperature of 25°C、 the payload of 70 kg、 full electric voltage and flat pavement. The factors like driving habit, environmental temperature, road surface condition, payload etc. will affect the continuous travel mileage. ② The travelling range is measured at the temperature of 25°C、 about15km/h、 the payload of 75 kg and flat pavement. The factors like driving habit, environmental temperature, road surface condition, payload etc. will affect the continuous travel mileage. Different models will also make different continuous travel mileages. ③Charging time varies with the ambient temperature and the battery capacity that may change in the course of time.
Factory default speed	25 km/h	25 km/h	
Maximum speed	Approx. 30 km/h ①	Approx. 30 km/h ①	
Endurance mileage	Approx. 15 km ②	Approx. 35 km ②	
Max. gradient	Approx. 15	Approx. 15	
Net weight	Approx. 11.5 kg	Approx. 12 kg	
Max. Load capacity	100 kg	100 kg	
Overall dimensions	1056*430*1100mm	1056*430*1100mm	
Motor rated power	250W	250W	
Max. motor power	500W	500W	
Battery specifications	36V 4.4Ah lithium battery	36V 8.7Ah lithium battery	
Charging requirements	100-240V AC 50~60Hz	100-240V AC 50~60Hz	
Charging time	Approx. 2.5 hours ③	Approx. 5 hours ③	
Tire types	8 inch solid tire for the front wheel and 8 inch pneumatic tire for the rear	8 inch solid tire for the front wheel and 8 inch pneumatic tire for the rear	
Brake type	Electronic brake and Foot brake	Electronic brake and Foot brake	
Optimal operating temperture	25°C	25°C	
Working temperature	-10~40°C	-10~40°C	
Protection grade	IP54	IP54	

2.4. Product Structure

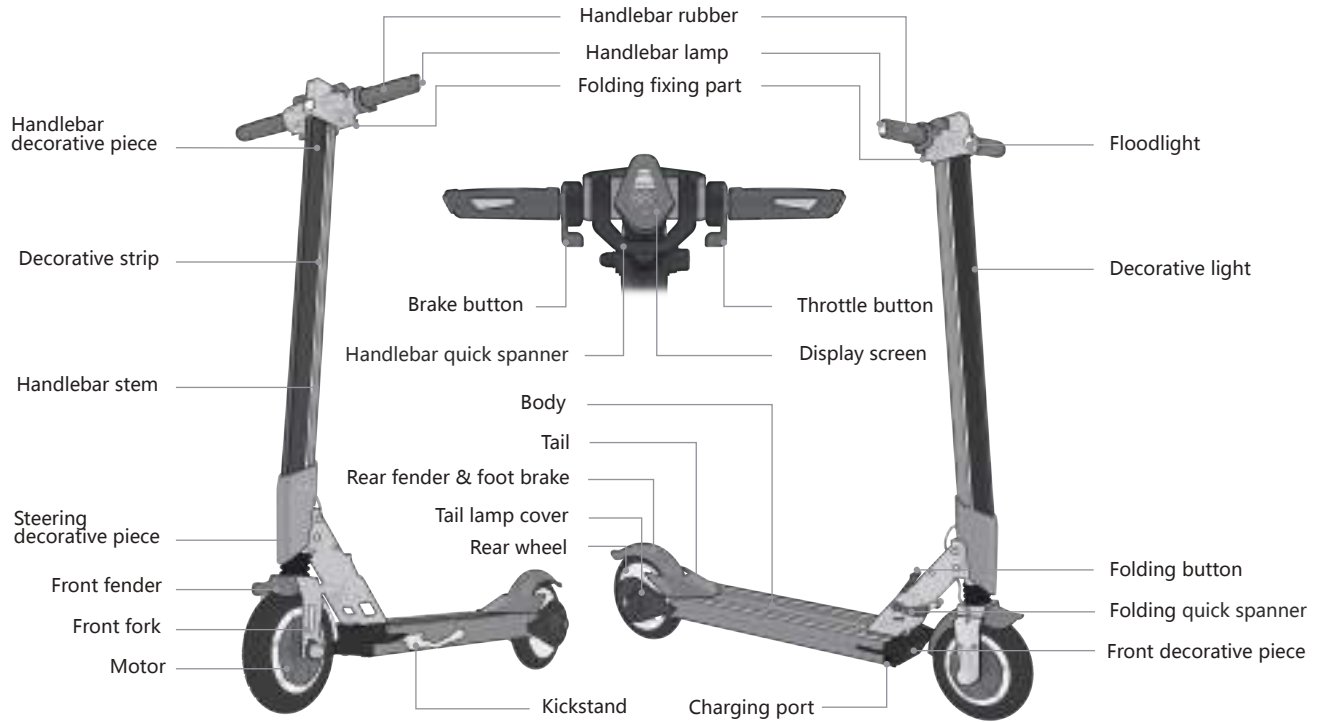

2.5. Packing Carton Check

Before delivery, the INMOTION E-scooter package includes the following parts that shall be checked when unpacking, consult with the local dealer or after-sale department of INMOTION in case of any missing.

•Scooter main body ×1 •Charger ×1 •User Manual ×1

WARNING!

Use of unauthorized parts and components or incorrectly installed parts and components may result in damage to L8 or even personal injury. In order to ensure quality and safety, all parts of L8 will be subject to the approval of Shenzhen INMOTION Technology Co., Ltd. and assured to be correctly mounted to L8.

Please do not try to stand on an L8 that is not correctly, effectively and completely installed.

Do not disassemble, refit L8 without permission, or it will cause irreparable damage of L8 and may result in personal injury.

2.6. Open L8

Step 1 : Press the folding button,
Help handle the direction toward the left body,
Until you hear a click sound,
then press folding quick spanner.

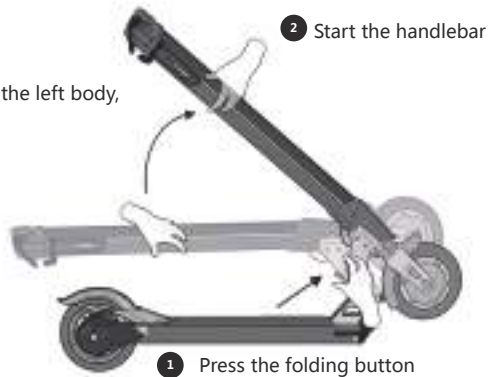

Step 2 : Open Handlebar quick spanner , then rotate the hand out to the side , Inserted into the middle , Pressing Handlebar quick spanner.

Step 3 : Hands holding the hand , you can use L8 normal through promote the body.

4 Open Handlebar quick spanner



7 Pressing Handlebar quick spanner

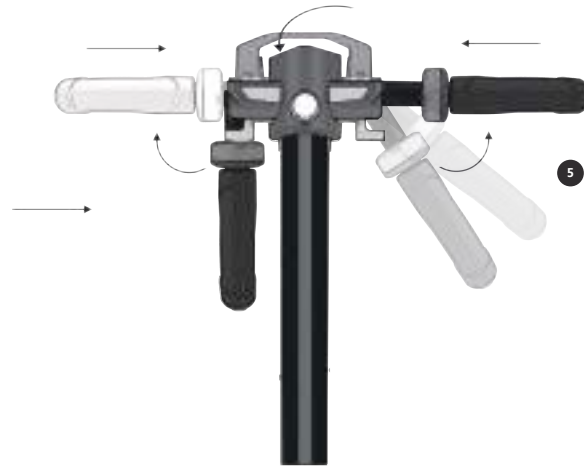

6 Inserted into the middle

5 Rotate the hand out to the side

2.7. Display Screen

The LED display screen is an interface that shows the operation status of the scooter :

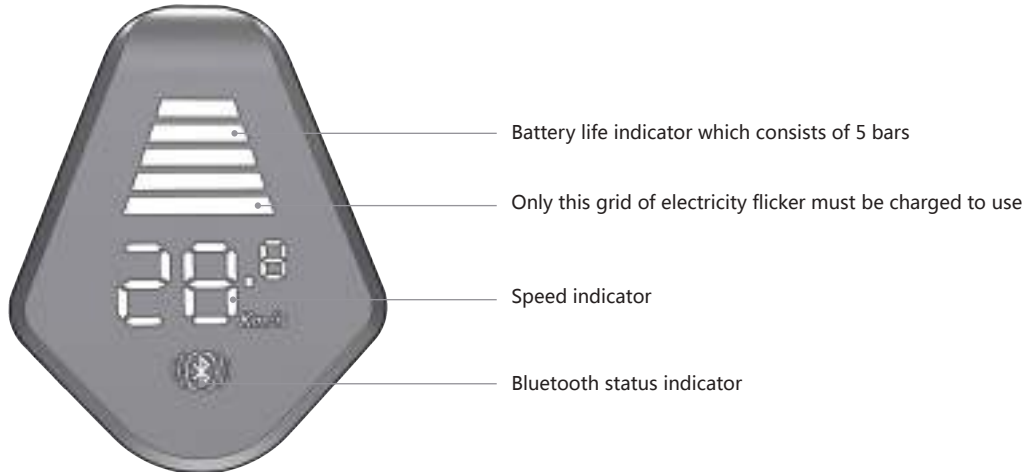

2.8. INMOTION APP

The INMOTION APP is a mobile software specially designed by INMOTION for its users, and can be used to control the scooter, make friends, publish messages, take part in INMOTION activities, purchase INMOTION accessories, etc. The English title of the L8 INMOTION APP is: INMOTION.

The INMOTION APP can be downloaded from the official website of INMOTION or related APP stores (for IOS, it's Apple App Store; for Android OS, Google Play)

The INMOTION APP features the following functions :

- Scooter control: locking, unlocking.
- Scooter status indication: providing information including speed, range, battery life, etc.
- Scooter parameters setting: Light color, top speed, drive mode, etc.
- Fault detection: conducting detection and estimation on the health state of L8.
- After-sales service: exchanging with INMOTION's service personnel and working out solution to your problems in a timely manner.
- Firmware updating: checking the latest scooter firmware updates released and updating it via connection to network.
- For more details about the mobile client's functions, refer to tips and help information contained in the mobile client, or download and read the instruction manual of the latest mobile APP from INMOTION's official website. In addition, new functions will be added to INMOTION APP on an irregular basis.

2.9. Pairing with INMOTION APP

- Open the APP and L8 , Search and choice for L8.
- Click connection and enter the initial password of 000000
- Appearance of  on the scooter screen signifies a pairing success

Download App



2.10. Scooter Working Modes

L8 features 3 working modes and here are some brief introductions to some important ones:

Working mode	Description
Accelerator mode	Accelerator press to achieve acceleration, the factory default for this mode, can be switched to other modes via mobile phone APP
Locked mode	When L8 is parked normally and connected to your mobile phone, you can switch the scooter to the locked mode by operating on your phone. In this mode, the throttle will cease to function. Only by operation via the connected mobile phone, can the scooter be released from this mode.
Error handling mode	This mode will be activated automatically when the system detects some error or warning, and in this case the system will take control of the scooter and bring it to a stop, and the same time, L8 will be flashing red light warning, After stop, Please put L8 for a period of time, reboot, if still can not be normal use, please contact INMOTION service.



NOTE: After L8 is off, still can keep the telephone APP related settings for the L8.

3. Battery and Charger

3.1. Battery Specifications

Various battery parameters are described in the table below :

Parameter	L8	L8F	Remarks
Battery type	Lithium batteries	Lithium batteries	①The voltage here refers to the voltage with moderate capacity of a lithium battery ②L8 is configured with 4.4Ah batteries, L8F is configured with 8.7Ah batteries
Rated voltage	36 V①	36 V①	
Charging voltage	42 V	42 V	
Capacity	4.4Ah②	8.7Ah②	
Battery weight	Approx. 1.2 kg	Approx. 1.7 kg	
Dimensions	L*W*H : 330*81*45 mm	L*W*H : 330*81*45 mm	
Working temperature	-10°C~40°C	-10°C~40°C	
Charging temperature	5°C~ 45°C	5°C~ 45°C	
Storage temperature	-20°C~45°C	-20°C~45°C	

3.2. Charging Method

step 1: The position of the charging port is at the front of L8, Open the Charging cover, and make sure that the Charging interface is dry.

step 2: Insert the charging port to the charging interface on the L8.

step 3: When the indicator of the charger is on in red color, it means it is charging; when the indicator turns to green from red, it means that the battery is fully charged. Stop charging at this time, as long time of charging will affect the service life of the batteries.

3.3. Safety Prompt for Charging

- Please charge the batteries every three month or after driving each time in order to extend the service life of the batteries to the maximum extent. Please charge in the suitable temperature environment.
- Failure to charge on time may lead to battery damages. As time goes by, the battery electric quantity will be gradually used up which will finally lead to over-discharging.
- Please use the battery, charger and cable supplied by the original manufacturers so as to avoid over-discharging risk.
- Please ensure that the charger uses the designated cable and with correct connection.
- Please ensure a well-ventilated environment.
- Please ensure that it is used in a dry environment. Never allow the charger or cable to contact with water, as this may cause an electric shock. Do not touch with wet hands, and in process of charging, immediately pull out the power plug in occurrence of any failure.
- Please make sure to pull out by the plug, do not pull out plug by the cable.
- Please do not allow the charger or cable to contact sharp or hot object.
- Make regular visual inspection of the charger and charger cable.
- In case of any obvious damages found with the charger or cable, do not use the charger to avoid further impairment but instead contact for replacement.
- Please do not repair the batteries, charger or cable by oneself, but instead, contact us for service in case of any problems.

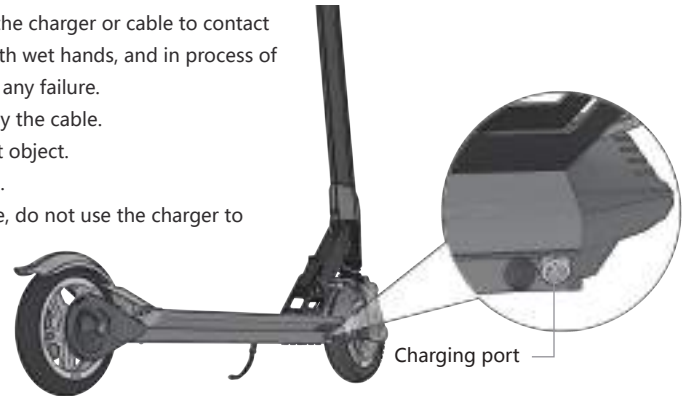

3.4. Protection against Over-discharging

The INMOTION E-scooter system has a built-in smart over-discharging protection system which will actively cut off the power when the scooter is in locking state or shutdown state and the electric quantity is too low. The scooter in an over-discharging protection state need to be awakened via charging, if the scooter remains un-awakened after half hour's charging, please contact the authorized dealer of the INMOTION Company or the INMOTION after-sale department.

4. How to use L8

4.1. Riding L8

L8 is a high-tech traveling and commuting device. Driving without learning about the operating specifications will cause unpredictable injuries. This instruction is made for green hands, especially the beginners of L8, stating in details on how to correctly drive L8. Matters needing attention in driving are also listed. Users shall read them carefully and drive L8 in accordance with the instructions.

4.2. Precautions before driving

During the driving and parking, L8 may produce wear and tear, which will reduce product performance. Thus before driving L8, the following items must be checked:

- All parts of L8 shall be checked whether they are fixed securely and intact without damage.
- Folding mechanism is locked.
- Sufficient electric power.
- Good state of the type.
- Whether the handle is fixed; loosened bolts and screws shall be tightened.
- You shall find an open area with flat surface for driving, at least an area of 4m * 20m, indoor or outdoor.
- You shall learn about the surrounding driving environment sufficiently to guarantee that it is free from the disturbance of cars, walkers, pet, bikes and other obstacles.
- A skillful assistant shall accompany you at side. The assistant needs to operate INMOTION E-scooter proficiently and know very well about precautions and driving methods in this manual.
- Do not trial drive on slippery and wet field.
- Safety helmet and protecting articles against the possible injuries shall be put on.

WARNING!

- Moisture will cause the brake working slowly. After cleaning L8 body, dry the brake at a safe place by air.
- This product must not be used under severe weather conditions(like raining, snowing or icy).
- Before using this product under any circumstance, please confirm whether the brake can work normally nor not.

4.3. Operating steps of beginners

- Hold the handlebar with two hands, Promote L8 and the power on.
- When the power on, Front decorative lights and tail lights will be lit.
- Step on the pedal with one foot; look ahead, another foot shall be on the ground forwardly, applying initial velocity, after the initial speed control level is activated, L8 can accelerate to travel forwardly upon starting accelerator handle.
- At that time, another foot also steps on the pedal. Two feet stand in staggered way front and back. Stands upright naturally and two eyes look ahead horizontally, like standing on the ground. Keep the balance of body.
- Lightly press the accelerator handle for acceleration. The degree of acceleration depends on holding degree on accelerator. Beginners shall lightly hold the accelerator handle and accelerate slowly.
- Rotate the handle can control L8 in direction. Due to the length of L8, you should pay attention not to swerve within the narrow space.
- While Scooter needs to decelerate or stop during the driving process, press fingers on brake button until scooter decelerates or stops.
- At the same time can also be used after stepping on the rear fender, also can make L8 slow down or stop.
- After starting the brake, APO (Automatic Power Off) of the right handle accelerator becomes invalid.
- When not using L8, parking for 1 minutes can be automatically shut down.

4.4. Body folding steps

- 1 : Open the Folding quick spanner.
- 2 : Forward nudge handlebar.
- 3 : Press the Folding button
(As far as possible with the second step at the same time) .
- 4 : Walking down the folding handlebar until a click sound.
- 5 : Folding can be completed.

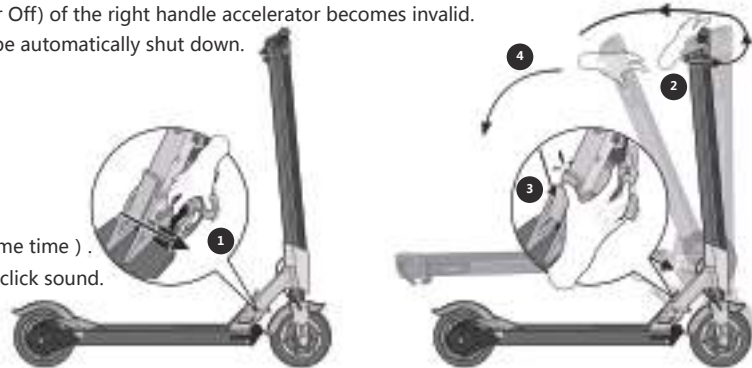

4.5. Switch lamp and active power off

In the case of parking and the power is on, Long press the brake button for 3 seconds, can turn on or off the lights



In the case of parking and the power is on, Both press brake button and throttle button to turn off the power supply.

5. Precautions for Safe driving process

L8 is a personal traveling and commuting tool. Strict inspection has been implemented on the technology and production. If the users do not use it in accordance with the safety warnings regulated in this manual, driving risks may occur. Anywhere or any time, falling, out of control or bumping, including violence of the driving manual specifications, may cause injuries, even death. To reduce risks and avoid injuries, users must read this manual carefully and watch the related safety video and abide by the following precautions.

- Please wear helmets and protection equipment while riding and driving.
- Please do not drive on the slopes over 15° gradient. Do not sharply accelerate or decelerate on slopes.
- Protect yourself from obstacles and slipping on road surface. Do not drive on the grass and cobbled road.
- Depth of driving into water shall not be more than 30mm.
- Forbid riding a Scooter to go up or down steps.
- Forbid driving on motor vehicle road.
- Forbid soaking in water.
- L8 is the transportation tool for only one person, prohibiting driving and riding by several persons at a time.
- Beginners who are older than 45 years old or younger than 18 years old shall drive accompanied by others for assistance.
- Make sure that the battery has enough power and tire pressures(5.0bar) are normal.
- Before mastering the driving skills proficiently, do not try to drive at a fast rate. Please accelerate slowly.

6. Care and Maintenance

6.1. Storage

- Unreasonable storage will cause inside lithium battery life shorter and other hidden dangers. L8 shall be placed at indoor dry places with suitable humidity and temperature.
- Avoid parking the electric scooter at sun-bathing places (even the trunk of your car) in that the temperature of the body and the battery from sunbathing may rise as high as 50°C, The battery function and product lifespan may be damaged.
- When L8 is not used, the battery will discharge automatically. The battery power shall be monitored within three months and charged in time to guarantee battery fully charge. Avoid the irrevocable losses from long-time storage of battery without electricity (deep discharge of battery)
- In winter, battery may lose the electricity power due to low temperature.
- L8 shall be charged fully before placing for a long time.

6.2. Cleaning

- Before cleaning, L8 shall be turned down. Charging wire shall be pulled up and the charging port shall be closed. During the rinsing process, water shall not flow into the battery-charging port.
- Use soapy water, clean water or soft cloth to rub the outer cover of L8. Prohibit using high pressure water gun to swash L8. The waterproof and water level of L8 shall be IP65 that is, spilling resistant and dust resistant. Thus, it is not allowed to dip L8 in water, which may cause L8 permanent damage.

6.3. Handing

- Battery and electricity devices shall not be treated as general domestic rubbish. Since you have made contributions to environmental protection by driving L8, in order to further avoid unwanted pollution.
- Please handle your electric Scooter and all the related components (battery) through authorization processing facilities.
- Please abide by the updated guidance notes. Please consult dealers or contact after-sale departments if you have any questions.

6.4. Inflation and Replacement of the Interior and Exterior Tires

- If the tire pressure is insufficient, please fill in time to ensure the normal tire pressure.
- If you get a flat tire or are in need of new tires, please contact an INMOTION authorized distributors or the INMOTION service department.

6.5. Handle loosening adjustment

If you find the right and left side of the handle is loose, please use M4 six angle wrench Lock the two screws on the lower position of the quick release wrench.

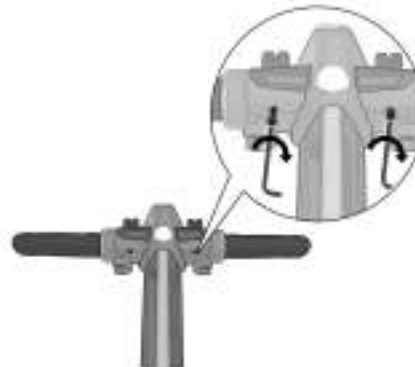

7. Contact and Legal Information

7.1. Feedback of issues

If you yourself or any other people you know have any questions or improvement advice when using L8, please feel free to contact us, and we will heed each and every of your question and advice, and do all we can to provide you with the best service.

7.2. Contact Us

ShenZhen INMOTION Technologies Co., Ltd.

Address: Shenzhen city Nanshan District Xueyuan Road No. 1001 Nanshan ZhiYuan B1 building 18 floor

Tel: 4000-1000-12 or 0086-755-26906865

Email: info@imscv.com

7.3. Following the Local Laws

L8 may serve as a smart and convenient travel tool, but it still can't replace other existing transportation means, thus do not try to ride L8 on public transportation roads. In some countries and regions, L8 is barred from public transportation roads. For detailed information, contact the related local authority, or you can also make contact with the authorized agent or the after-sales department of INMOTION.

7.4. Version No.

Version 1.1

8. Legal Statement

8.1 Statement about the Product

To ensure your riding safety and well riding experience, we specially request you to comply with the following requirements when using the product.

- Before riding, make sure to read carefully and understand fully L8 User Manual.
- Do not let people who haven't carefully read and fully understood L8 User Manual use your L8.
- Strictly comply with the age requirement stated in L8 User Manual that only people between 12 and 60 may use the product, and do not let those out of that range ride your L8.
- Pregnant women or people with psychological unfitness shall not use L8.
- When feeling unwell physically or mentally due to illness or under the influence of medicine or alcohol, do not ride L8.
- L8 is designed for only one rider, and never try to ride double or more, or ride the scooter holding a child or load.
- Before riding L8, make certain that both your physical and mental conditions enable you to freely get on and off the scooter and control L8 well, even without the help of others.
- Assemble all components correctly and properly in strict accordance with the assembly instructions in L8 User Manual. Improper assembly may bring about risks of loss of control, collision or fall-off. When assembling the scooter, take care to apply appropriate force, as either screwing too tight or too light may cause damage to the scooter or malfunctions. Special note: do not conduct assembly or service with the power turned on.
- Do not try to modify or service L8 by yourself or let personnel unauthorized by INMOTION do the work. Should any problem happen, feel free to contact INMOTION at any time, as this is your most reliable choice.
- Before riding, always make certain that no abnormalities such as loose parts, damage or malfunctions exist on L8.
- The front wheel of L8 is a pneumatic one, and charge pressure or tire pressure not maintained properly may lead to travel instability or easy damage, or even traffic accidents in extreme cases. Measure the tire pressure at least once each month and measure again before starting a long-distance riding.
- Should you spot any loose part, damage, abnormality or malfunction during use of L8, stop using it immediately, and carry out troubleshooting and repair timely to avoid dangers.
- Prior to charging the scooter, make certain that the charging port is dry and free from malfunctions and foreign objects. Only a correct receptacle (100V-240V/50HZ-60HZ) can be utilized for charging. When the scooter is being charged, keep children and pets away and make sure there are no inflammable materials nearby.

- L8's battery must be stored in environments with a temperature ranging from -20 to 45°C. Do not place L8 where the temperature is over 45°C. When the ambient temperature falls below -20°C, the battery will enter into a self-locked state, and can't be charged or used. If that happens, first bring L8 to a warmer place to unlock the battery for charging and using.
- Should any leakage or other abnormalities (including breakage, emission of odd smell or smog, overheat, etc.), stop using the product immediately and prevent the battery from contacting other objects.
- Without permission, never try to open or disassemble the battery, or perform any irrational operations on it or use it in an irrational way.
- Depending on the battery state and environmental conditions, fully charged L8 (the display screen showing 5 bars of power) will have a standby time of approximately 180 days, and non-fully charged L8 (the display screen showing 1 bar of power) will have a standby time of about 90 days. Bear this in mind and avoid irreversible damage to the battery caused by failure to charge it timely.
- Do not wear high heels or other unsuitable shoes, too loose or other unfit clothes for riding L8, and always wear specialized protective gears when riding it.
- When you are to ride L8, it's strongly recommended that you wear a pair of safety goggles, lest dirt, dust or insects harm your eyes or undermine your riding safety.
- Never try to ride L8 in rainy weathers or on wet roads, as wet and slippery roads may reduce the tires' resistance and lengthen the scooter's braking distance, and may also lead to loss of control or other accidents incurred by tire skidding.
- Use soft cloth to wipe and clean the scooter body, and never try to flush it with powerful water jets or a high-pressure hose, nor shall you immerse L8 in water, or else dangers such as uncontrollable malfunctions, abnormalities or accidents may occur.
- Never try to ride L8 under adverse environmental conditions such as bad weathers, low visibility, poor illumination, etc., nor shall you ride it when feeling exhausted.
- Nights or other environments with poor light conditions make it hard for riders, drivers and pedestrians to notice each other in a timely manner, therefore it's strongly recommended that you do not ride the scooter under the above-mentioned conditions to avoid potentially serious dangers.
- When riding L8, always pay close attention to the changes of the road and surroundings, and always ride cautiously, lest any harm be inflicted on yourself or others.
- Do not ride the scooter up/ down stairs, in an elevator, through a revolving door or in any other adverse road conditions or environments.
- When riding L8, always watch out for overhead obstacles.
- During riding, should you encounter an abrupt slope, an uneven road or any other terrain conditions you haven't met before, do not try to risk riding through.
- Do not try to turn abruptly at a high speed or brake suddenly on a slippery ground, as these kinds of actions may easily cause the scooter to skid and render it uncontrollable.

- Ride L8 on bike lanes, and never ride on motor vehicle lanes or any other inappropriate sites, and strictly abide by traffic rules and other related regulations. When approaching or passing a crossroad, a motor vehicle lane, a turn, the space in front of a gate, etc., slow down and take care to avoid the pedestrians, and meanwhile, you should also watch out for dangerous behaviors by passing vehicles and people that may pose a threat to your own safety.
- In riding, always pay close attention to nearby vehicles, pedestrians, potholes, sewer covers, railroads, expansion joints, construction areas on the road or sidewalk, debris or other obstacles that may pose a threat to your own and others' personal or property safety.
- Never try to make or answer phone calls or do any other things that may distract yourself, so that you can always concentrate on monitoring your surroundings.
- Ride on the designated bicycle lanes or close to the road edge along the direction of traffic as allowed by local laws and regulations, and never go against the direction of traffic.
- When you go out riding your L8, do not cut in other vehicles' or pedestrians' way.
- When riding L8, do not try to put your hand on another vehicle and get yourself dragged along. And avoid inappropriate behaviors like performing stunts or X-sports, etc.
- When you need to ride L8 to a remote area, do not go alone. Even if you have partners on your journey, you still have to prepare yourselves well for potential risks.
- L8 is a personal travel tool made for short journeys, and shall not be used for any other purposes such as goods delivery, etc.
- Data and Parameters of L8 may vary with different models, and they are subject to change without prior notice.

8.2 Personal Information Protection Statement

- Your personal information hereof is that you voluntarily input when you go through the registration and authentication process to pair your mobile phone with L8 to bind them via the INMOTION mobile client (hereinafter referred to as "the APP"), and that we collect during your using process, including but not limited to your name, gender, age, address, contact information, occupation, as well as the time when and the place where you access our service, etc.
- While you are using the APP, the personal information we collect in the processes of owner authentication, product serial No. activation, questionnaire survey, after-sales tracking and callback, opinion or advice seeking for products or services, activity participation, etc., are eventually used only for presenting you with even better products and services, and improving and enhancing your using experience.
- You have every right not to offer your personal information, but without your personal information, we may not be able to provide you with better products or service, and even your experience of using our products and service may get compromised.
- Your agreeing to provide any personal information will be taken for your consent to allowing INMOTION to use the information and disclose it to affiliated companies. Use by INMOTION and its affiliated companies includes but is not limited to that by employees, consultants, agents, suppliers, partners, etc.

- Fulfillment of any of the following conditions will be taken for your consent to allowing INMOTION to share your personal information with related third parties:
 - 1)Your special authorization;
 - 2)Mandatory requirements put forward by related laws or regulations, or by government authorities (including judicial authorities);
 - 3)Execution of applicable service terms (including investigation into irregularities that may exist);
 - 4)Dealing with issues concerning fraud, security, technologies, etc.;
 - 5)Protection of users' or public interests, property or safety from damage, within the range required or allowed by laws;
 - 6)Necessities in special and/ or emergency conditions; The use, transmission and storage of your personal information can be carried out in an electronic way, and may happen either domestically or abroad.
- To get better using experience and service, you fully consent to receiving push notifications about products, services or relevant activities from INMOTION and its affiliated companies on an irregular basis.
- We will take sound and secure measures to protect your personal information from unauthorized disclosure or use, and also urge other related parties who may obtain and use your personal information within the framework of this legal statement to stringently protect your information. You consent to the procedure that we will decide the time for storing and retaining your personal information based on the time as required by the intended purpose or stipulations of any applicable agreement, law or regulation.
- You agree to fully exempt the receivers and/ or users of your personal information from any claims for compensation, liability and loss investigations caused by disclosure and use of your personal information within the framework of this legal statement, unless the aforementioned claims for compensation, liability and loss investigations are caused by direct intentional behaviors or gross negligence from the receivers and/ or users.

8.3 Intellectual Property Statement

Unless otherwise provided by laws and regulations, or as otherwise agreed, all rights to the products and accessories, APP and all intellectual property rights pertinent to the websites (including but not limited to copyrights, trademark rights, patent rights and related application rights, implementation rights and licensing rights) are reserved by INMOTION. Without prior written consent by INMOTION, no illegal use or any other disposition are allowed.

This statement is governed by the Laws of the People's Republic of China. INMOTION will not assume compensation or any other responsibilities for any claims, liabilities and damages caused by or may result from violation of this legal statement by consumers or any other third parties.

This legal statement constitutes an indispensable part of our products (thus when reselling the product, make sure to transfer this statement to the buyer together with the product). You may accept all terms of this legal statement to use our products. Your option to use our product will be taken for your consent to accepting all terms of this legal statement and taking any possible risks and responsibilities involved. Should you not accept all terms of this legal statement after you purchase our product, you shall return the product to us and make sure the returned product and its packaging are free from any damage and will not affect its resale.

9. Product Warranty

Dear customer:

Many thanks for your purchasing our product!

After purchasing our product, please provide your correct, complete and authentic personal information, write the serial No. of the purchased product into the warranty card, ask for a valid invoice and keep it properly so as to be able to use our warranty service should any issue occur in future.

To ensure high-quality service, INMOTION promises that it will provide repair, replacement and return services free of charge for products in accordance with our warranty policies (only products purchased on the Chinese mainland). Except for costs including insurance, delivery, transportation, etc., the warranty service is provided free of charge.

9.1 Scope of Warranty

◆ All products purchased from INMOTION's official online outlet, within 7 days from the date of sale (herein, the date of receipt by the customer is taken as the date of sale), are covered by the "7-day no-reason return" policy in line with the rules of the platform. The returned product must be the original one and its packaging shall be free from damage and will not affect its resale. Besides, the delivery cost shall be paid by the customer.

◆ With 7 days from the date of sale (herein, the date of receipt by the customer is taken as the date of sale), should any quality issue occur and later be confirmed by the manufacturer's inspection to be caused by the product itself, the product can be returned, replaced or repaired free of charge.

◆ With 15 days from the date of sale (herein, the date of receipt by the customer is taken as the date of sale), should any quality issue occur and later be confirmed by the manufacturer's inspection to be caused by the product itself, the product can be replaced or repaired free of charge.

◆ Should the customer make a return or exchange request, but fail to send the product back within the specified deadline, the customer's return and exchange rights will no longer be considered valid. Loss incurred by causes irrelevant to the product itself during the return and exchange process, shall be borne by the customer.

◆ Within the warranty period, should any quality issue be confirmed by the manufacturer to be caused by the product itself, the manufacturer will provide repair service free of charge. The starting date of the warranty period is the date specified in the legal, authentic and valid proof of purchase provided by the customer. Should the customer not be able to provide a proof of purchase, the day 90 days after the date of production shall be taken as the starting date of the warranty period.

1. The warranty periods of different scooter parts are shown in the following table:

Part	Warranty period	Quality assurance
Body、 Handlebar stem	12个月	Natural cracking, fracture and other phenomena
Motor、 Driver、 external charger	12个月	Due to poor manufacturing performance and failure to repair
Floodlight、 Decorative light、 Tail lamp、 Kickstand	6个月	Due to poor manufacturing performance and failure to repair
Battery	6个月	Replacement of the new battery at 6 months of capacity less than 65% of the representation capacity
Rear wheel、 Handlebar rubber、 Decorative cover		The wearing part is not in the scope of warranty

2. The following circumstances will not be covered by the warranty, and the customer has to pay for the repair :

- The "three guarantees" validity period has expired
- Damage incurred by man-made causes
- The scooter has traveled over 2000km (For the vehicle which has accumulated more than 2000km of mileage, we propose to repair and maintenance and replace the tire according to the tire wear condition.)
- Any damage caused by failure to follow the requirements in the instruction manual to correctly assemble or use the scooter
- The serial No. has been deleted or modified
- The serial No. bar code or model on the product warranty card doesn't coincide with the product itself
- The product has been disassembled or repaired by personnel unauthorized by INMOTION
- Daily wear and tear (including wear and tear of the scooter shell, handle grips, tires, etc.) that does not affect the product's functionality
- Damage caused by accidents or improper use, such as physical damage, fall-and-break damage, collision damage, severe oxidation, etc.

- Damage caused by overload, forcing through obstacles (including but not limited to riding down stairs, hitting the ground, etc.), performing X-sports stunts, etc.
- Damage caused by disassembly, transportation, loading/ unloading, etc. in the process of return for repair
- Damage caused by fire, liquid immersion, freezing, earthquake, or other abnormal storage conditions or force majeure
- Depletion of wearing pieces such as the packing material, different types of technical documents, etc.
- Products used for commercial purposes will not be covered by the warranty
- For malfunctioned products whose warranty has expired, INMOTION provides paid repair service, and as to the charging standard and accessory prices, you can contact our after-sales personnel for more details

3. For malfunctioned products whose warranty has expired, INMOTION provides paid repair service, and as to the charging standard and accessory prices, you can contact our after-sales personnel for more details.

9.2 Product Repair Service Policies

1. Customers can call our official technical support number 4000-1000-12 for after-sales help, or directly contact the dealers from whom they bought the products and ask them to facilitate the after-sales service process. For detailed after-sales service policies and procedures, visit our official website: www.imscv.com.
2. After receiving the malfunctioned product from the customer, we will initiate communication with the customer about the malfunction cause, liability, repair cost, estimated time needed to rectify the malfunction, etc. When no more dissent is left, the repair process will start.
3. For products that have been repaired by us, within one month after completion of the repair, the product will be covered by our free-of-charge warranty service.

 **NOTE : Outside mainland China to buy L8' s product warranty policy, please consult the local agents and distributors**

Product Warranty Card

Customer and purchase information registration

Customer name _____

Serial No. _____

Purchase date _____

Contact number _____

Email _____

Address _____

Dealer name _____

Dealer address _____

Repair record

Serial No.	Troubleshooting and service record	Service station	Repair time
1			
2			
3			
4			
5			
6			

Note: the product should be repaired with the warranty card, invoice, the scooter, charger and battery pack, etc.

Product Quality Certificate

This product is qualified by passing QC inspection and allowed to be sold on the market.

The warranty card (It takes effect upon manufacturer' s seal and pasting with serial number) and regular sales invoice is effective maintenance certificate. Please keep the warranty card properly.

Release date :

QC Qualified Seal :



Download App



Follow wechat account

Customer Service Center : 4000-1000-12 0755-2572-2469